

# FIVE MILE - A WHOLE NEW SUSTAINABLE TOWN

*MARK KESSNER*

Principal Building Services Engineer – Sustainability Knowledge Leader  
MWH New Zealand Ltd, Millennium Centre, 600 Great South Road, Greenlane, Auckland  
Tel: 09 580 7631, Cell 021 767 469, Fax 09 580 7600,  
[mark.kessner@mwhglobal.com](mailto:mark.kessner@mwhglobal.com), [www.mwhglobal.com](http://www.mwhglobal.com)

## ABSTRACT

**Project Description** –The \$2.2billion project 33 hectare FIVE MILE Township, sited in Queenstown will include over 700,000m<sup>2</sup> of mixed use, office, retail, commercial, hotel, apartments and sports and educational facilities and 8000 underground car park. Population numbers are expected to be in excess of 10,000 residents and 5,000 transient population. Included in the mix are also a campus for an international university and a regional bus station, town hall, department stores, grocery stores, cinema, and hotels will serve to anchor the main streets and town centre.

It is the first town in New Zealand where all buildings shall be designed with an intent to achieve a minimum of 4 star Green Star design rating. In addition numerous buildings shall be designed in an intent to achieve a 5 star rating and the town will hopefully provide the first 6 star rated buildings in New Zealand. (The project is currently in the early rounds of discussion with the New Zealand Green Building Council and is working towards a rating which if achieved will be a very pleasing result for the project.)



## KEYWORDS:

Sustainable, Urban Design, New town; Efficient; Innovative; Green Building, Technology;

## INTRODUCTION

**VISION** - As described by Property Ventures and a significant part of our overall design brief:-

FIVE | MILE will be a town that celebrates everything the region has to offer - a place that reflects the rich culture and heritage of one of New Zealand's best-loved regions.

The town is based on a carefully considered urban plan, established under the guidance of one of the world's foremost practitioners of traditional neighbourhood development, DPZ Pacific - Both the setting and the community plan provide a rich source of inspiration for an architectural development that will become an international showcase of urban design.

FIVE | MILE will maintain the rural character of the area, in a community designed on a human scale where everything is within an easy walk.

FIVE | MILE will also be established with a strong sense of place - a town that has grown naturally, in a style that reflects the region's rich architectural heritage.

FIVE | MILE will also be built on the principles of best environmental practice, with every member of the project team striving to ensure the development is of benefit to the local environment. Every aspect of the town will have at a minimum a neutral effect on the environment.

FIVE | MILE will be designed to protect and enhance the local environment, preserving the rural character of the area and the spectacular scenery that surrounds it.

**CLIENT BRIEF** - And as a consultant that's where we fit in. Our brief and just as importantly our combined Vision with Dave Henderson is to create one of the Worlds Most Sustainable Towns. Simple and concise and our commitment to that brief is well established and was our goal well before we were appointed.

The most sustainable town is a very 'Big Audacious Hairy Goal' but without that possibly overly ambitious goal the desire to try and achieve the Vision might not be realised.

A learning tool" indicates to me how we need to view the world and how the life ring shown is how we need to protect our world to be enjoyed by our children and importantly our childrens' children.



Fig 1 -Image courtesy of the World Business Council for Sustainable Development

FIVE | MILE attempts to give a complete picture of the concept of sustainable development. In all its elements and stages it tries to address and manage the deluge of information on sustainable development and provide easy and simple solutions to meet those expectations.

## OVERALL DESIGN PHILOSOPHY

Our overriding design philosophy for all our projects is Environmentally Sustainable Design (ESD). This by many is seen as innovation but for sustainable engineers, it is the benchmark for all our designs. For FIVE MILE all designs are and shall continue to be energy, water and resource efficient and will be specified with materials that do not harm the environment.

The initiatives supported on all our projects are 100% in line with the NZ Green Building Council requirements and beyond. All building design shall be in line or equal to 4, 5 and 6 Star NZGBC model requirements with significant reduction of CO<sub>2</sub>.



Fig 2 – 3D image of Five Mile - Townhouses

The Design Team are using FIVE MILE and the scale of the project to support the NZGBC and assist in the development of rating tools for high- use building types as additions to the current suite of tools.



Events like the G8 Summit and organisations like the World Bank are also using offset schemes to become carbon neutral. Artist like The Rolling Stones and Pink Floyd have made albums or tours carbon neutral. (ref: [www.wikipedia.com](http://www.wikipedia.com): 2007)

So there you have it. Simple. We can buy some land up over the hill and plant some trees on it and we are . Totally Carbon Neutral??

So if being Carbon Neutral is not enough then what is the definition of a totally sustainable town?

So what is Sustainable Design when applied to a building or in the case a whole project, a whole new Town?

### **SUSTAINABILITY FOR FIVE MILE?**

One of the best description I've come across is as described by the **Ministry for the Environment**:-

A sustainable building, and its fit-out or refurbishment, considers the environmental, social, and economic impacts over the "life cycle" of the building. If properly designed, constructed, and operated, a sustainable building will require less money and fewer resources to operate, and will be healthier for its occupants.

Buildings are "sustainable" when they are designed, built and operated with low environmental, social, and economic impacts (or actually start to have a positive environmental impact) while enhancing the health, welfare and quality of life of the people that live and work in them.

It is a common myth that it is possible to make a building sustainable simply by adding some energy-efficiency and water conservation measures. While they are commendable in themselves, such improvements miss the point that there are many things that need equal consideration if a building is to be sustainable. If sustainability is not treated as a "whole" and only some elements are introduced, you put the sustainability of the building at risk.

In practice, a sustainable building needs to have performance targets in the following areas: Energy efficiency, Water conservation, Materials, Indoor environmental quality, Site location and ecology, Waste minimisation and Transport.

There will be other sustainability issues relevant for different organisations and their operations. However, the seven areas above are relevant to all building types and these should be considered as prerequisites for any building project.

Now add to the above list that the building/ site/ project shall also be or be very close to Carbon Neutral, then to me and to what we are trying to achieve on FIVE MILE is the true definition of a Sustainable town and with the help of the New Zealand Green Building Council we now have a range of tools that can help us measure the buildings against those values and traditions.

## SO HOW DOES ALL THAT RELATE TO FIVE MILE

So now we are aware of where we are heading what are we doing on FIVE MILE that warrants attention and how can that be applied to other projects across New Zealand and also across the world.

In line with previous statements that all buildings within FIVE MILE shall be equal to the NZGBC of 4 Green Stars the following items are a given part of the design philosophy for FIVE MILE.

However there are also some attributes that are being built into FIVE MILE that are pushing the boundaries of

Sustainable Design on a scale not seen before in New Zealand.

Innovation and being innovative are simple words to say but with all clients the results need to be demonstrated.

Often comments such as we need to be innovative lead to quite often more of the same with a slight twist and a large claim of INNOVATION. We think of innovation as something completely different. Innovation simply means 'To innovate'. On FIVE MILE there are a high number of innovative options being implemented. Some of the sustainable attributes are:



Fig 4 – 3D images of typical back street Five Mile



Fig 5 – 3D image of part Five Mile

### Management

- Independent building commissioning and tuning by Green Star Accredited professionals.
- Building Users' guide all building occupants.
- Energy Performance Contract and greenhouse management plans.
- Comprehensive environmental management
- Comprehensive waste management plan (WMP) recycled and/or reused 80 per cent of waste by weight during construction. A first for Queenstown and pioneered by FIVE MILE

### Indoor Environment Quality

- Outside air capability providing 'free cooling' when conditions allow.
- Thermal modelling to ensure minimal temperature fluctuations
- External solar shading (Natural Green solutions being explored)
- Automated ventilation system using outside air, linked to a weather monitors.
- Building Management System controls internal temperatures and ventilation based on occupancy.
- Increase in the minimum indoor ventilation rates between 50% and 100% when compared to the NZ Standard.
- High performance glazing, operator controlled blinds and shading screens.
- High frequency dimmable ballasts and smart lighting systems.

- High thermal comfort performance.
- Decrease in internal noise levels.
- Low-VOC (volatile organic compound) content used throughout for insulation, carpets, adhesives, sealants, composite wood products and paints.

#### Energy

- Design in an attempt to achieve 4, 5 and 6 Star NZGBC model requirements with significant reduction of CO<sub>2</sub>
- Shared plant with +700,000m<sup>2</sup> of other mixed use buildings, giving economies of scale, better shoulder loadings and greater redundancy
- High efficiency fully recyclable LED, T5 etc light fittings with automatic light sensing.
- Using solar for hot water energy
- Up to 40% reduction in energy use when compared to conventional non green buildings.
- Reduction in office lighting power density.
- Energy producing vertical transportation (Lifts)

#### Transport

- Provision of bicycle, shower and locker facilities.
- Size and total number of car spaces reduced and 28% of car parking spaces for small cars.
- Central location with a FIVE MILE developed bus terminus with good links to local networks.
- A walkable 5 to 6 minute catchment for 90% of residents and visitors to all uses, amenities and transport opportunities.

#### Water

- Significant reduction in water consumption. 100% reuse of rain water via Aquifer recharge.
- 5A rated shower heads
- Dual/ Low flush toilets, electronic on-demand taps and showers.
- Solar hot water to supplement site wide hot water.
- On site green water recycling and rainwater collection.
- Cooling tower water consumption eliminated.

#### Materials

- Recycling facilities for all waste.
- Provision of flexible shell and core with fully integrated fit-out.
- Promote the high use of recycled materials in construction methods.

#### Emissions

- Near-zero indoor air pollutants
- Zero Ozone Depletion Potential (ODP) of all refrigerants and thermal insulants.
- Refrigerant leak detection and monitoring system.
- Management of all stormwater on-site up to a 1-in-20 year rain event and for above the 1:20 year storm by use of adjacent FIVE MILE developed sports stadium.

#### Pollution

- All refrigerants will have Ozone Depleting Potential (ODP) and Global Warming Potential (GWP) of zero
- 100% on site Stormwater disposal, no connections to local network
- Sustainable insinkers to reduce solid waste
- Zero upward light pollution

#### Innovation

- Sensor-controlled air and fan coil movements, including
- CO sensors located in the car park.
- Photovoltaic roof mounted grids with the potential to provide some buildings with zero grid energy consumption.
- Development of 100% self-sufficient buildings – A short term and long term vision

- Ground water sourced energy for site wide air-conditioning and heating, reverse cycle heat pumps reducing overall energy consumption by 40% and capital cost by 20%. A world first on this scale.
- No chillers for air condition, replaced with simple static heat exchangers.
- Sustainable insinkers to reduce solid waste. (Current research indicates this to be worlds first)
- Through the Façade ventilation system eliminating the need for Roof top Air Handling Units, eliminating expensive horizontal and vertical ducts and plant costs and space provisions.
- Maximised daylight, dimming and lower overall lighting levels with increased uniformity.
- CO2 Emission Reduction - Buy Local Policy: In order to maximise the reduction in world wide CO2 emissions materials specified for the project shall in the first instance be sourced from New Zealand in all cases, only with the Clients authority shall overseas products be specified.

We have elected three innovations that we shall look at in more detail:-

- **THROUGH THE FAÇADE VENTILATION SYSTEM**
- **COMPARATIVELY FREE AIR CONDITIONING VIA GROUND WATER LOOP AND**
- **ENVIRONMENTALLY FRIENDLY INSINKERATORS**

## THROUGH THE FAÇADE VENTILATION SYSTEM

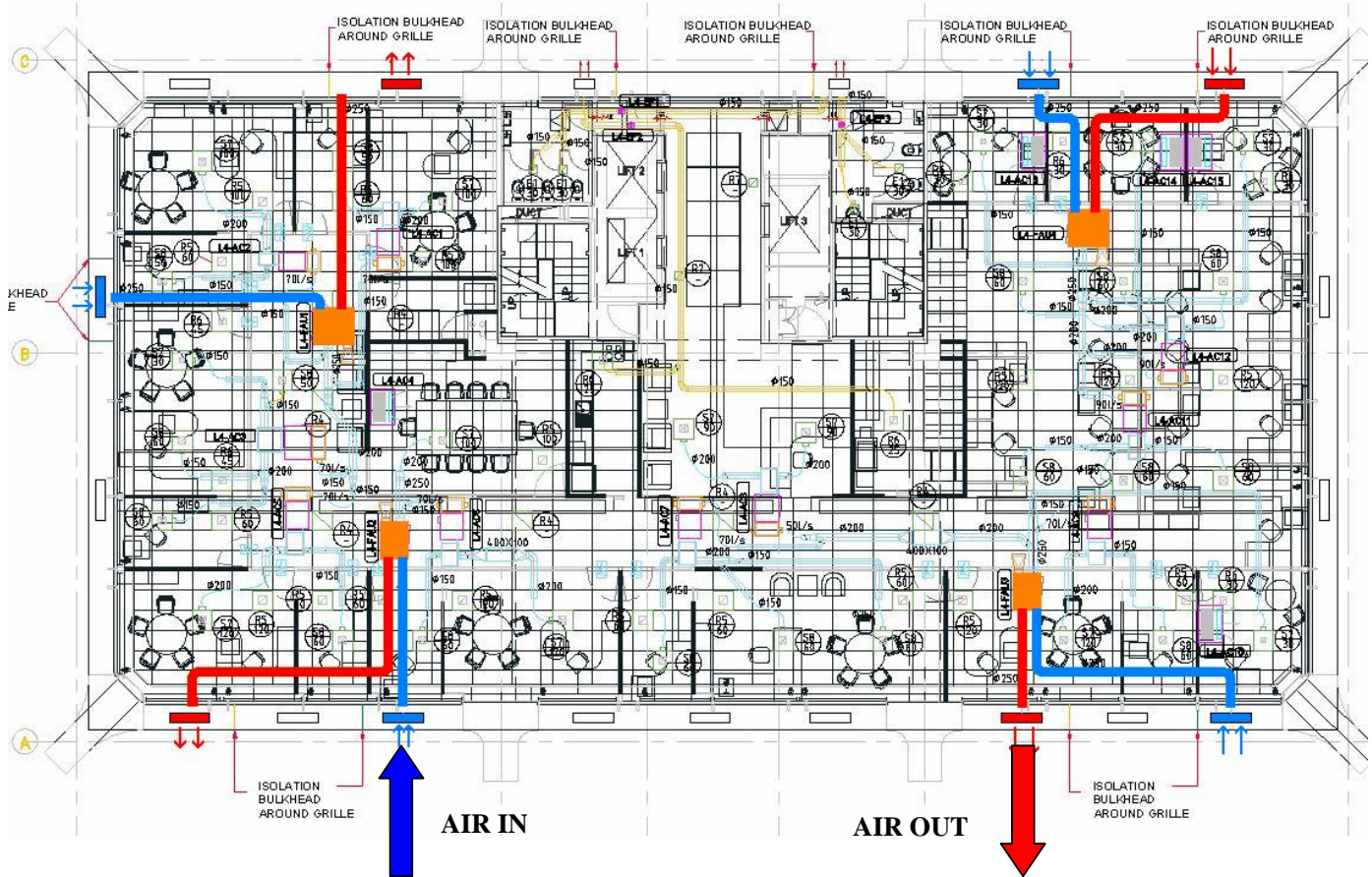

A significant cost saving, space saving and time saving innovative option that is being implemented on FIVE MILE is a significant rethink of the 'standard' approach to air conditioning. via a new concept of a 'Through the Façade' ventilation system that saves the project hundreds of thousands of dollars in time, plant space allowances and plant equipment costs.

The overall concept for the air quality and space conditioning system is a design that removes the need for roof mounted air handling units and the vertical ducts and riser shafts but still provides increased fresh air capability via an especially innovative through the façade ventilation system direct to the ceiling void.

This solution provides the lowest energy returns for air conditioning by taking advantage of free outside air cooling when conditions permit. The system also removes the space requirement for vertical risers, removes the need for the large vertical and horizontal ducts and removes the need for air handling units. And provides the building owner with more area per floor and hence increased efficiencies of the overall building.

A true WIN WIN situation. Not only are the energy savings significant but the associated reduced capital cost, space reduction and embodied energy savings associated with the design provides instant pay back on the innovative and very sustainable solution.

The HVAC and lighting design enable the fit out to operate at or potentially above the 5 Star NZBGC fit out rating and the concept design exceeds the Green Star benchmarks for outside air supply.

## VIRTUALLY FREE AIR CONDITIONING/ HEATING

“Where is the innovation?” – Heat Sink Ground Water Loop?

An obvious option for the building services heating and cooling is to embrace the availability of the ground available on the site and use this ground and its incumbent temperature as a single large heat sink to heat and cool the water as needed and thus provide water to feed into the primary energy source for the air conditioning and heating requirements.

One of the biggest energy loads is likely to be the air conditioning and space heating.

What better opportunity than to utilise the available and constant ground temperature to replace a significant demand on the high energy demanding refrigeration chiller's with a simplistic pumping and heat exchanger system. In summer this solution can provide up to 30% energy costs savings for the air conditioning with the added benefit of a reduction in the amount of installed plant required for the project and hence there are also savings in the associated capital cost of that plant.

Another Win Win Situation.

At FIVE MILE in Queenstown NZ we are using this system to provide the heating via reverse cycle heat pumps and cooling options via water to water and water to refrigerant heat exchangers for over 300 buildings and over 700,000m<sup>2</sup> of built area.

The potential savings are:

- **SIGNIFICANT ENERGY SAVINGS**
- **CONSTRUCTION COSTS SAVINGS**
- **PLANT SPACE SAVINGS**
- **MAINTENANCE SAVINGS**

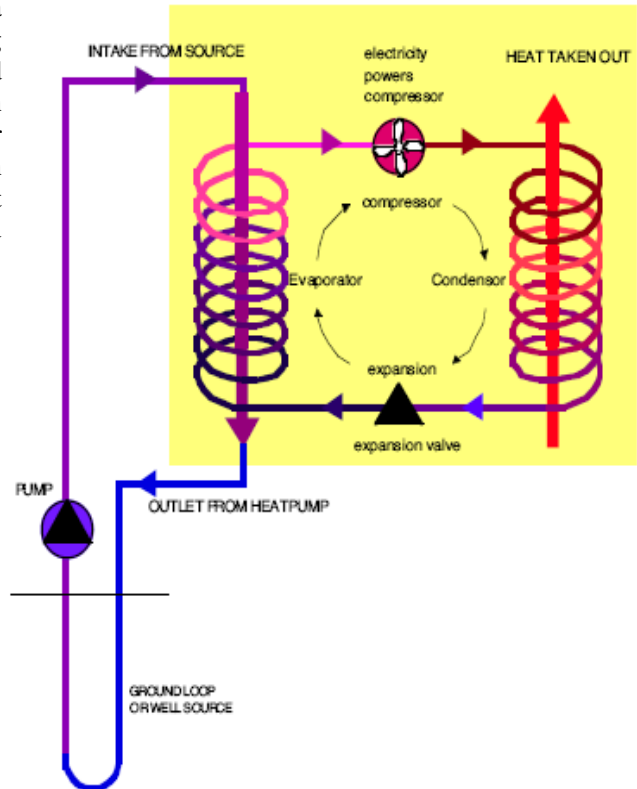

The earth's incumbent ground water resource in the Queenstown area in the form of an underground high flow aquifer from the Queenstown lakes to the Shotover river provides a natural resource, which is being used in conjunction with heat pumps to provide supplementary energy for air conditioning, heating and hot water. CO<sub>2</sub> emissions are much lower than gas fired boilers or direct electric heating systems. Within the ground we have completed bore holes and found temperatures are remarkably even at 10°C and chilled water produced by refrigerant chillers is also remarkably even at similar temperatures. Ideal for a ground water heat sink-based air conditioning and heating system. All water is extracted, moved through heat exchangers and returned.

This innovation option alone does not just save operating costs but also provides the significant added benefit of reduced capital cost. Sustainable design that is not only affordable but is also capital cost positive to the project. A solution that we strive to deliver in all its thinking with regards to green buildings.

## ENVIRONMENTALLY FRIENDLY INSINKERATORS ?

Hon Marian Hobbs Minister for the Environment said at a Major Retailers workshop in 2002

‘Why bother worrying about waste? Because waste is bad - it’s bad for our health, bad for the environment and bad for the economy. It costs. New Zealand has a waste problem, and it’s getting bigger and more expensive to deal with each year.’

Marian went on to say; ‘Maceration and **domestic insinkerators are not the way**. Why do we treat water to a standard good enough to drink, only then to use it to flush wastes down the sink and off to the sewage works through already often inadequate reticulation systems. An expensive plant is then used to digest the waste and create sewage sludge, which is then transported to the landfill and buried’.



And yes on the face of it insinkerators are not environmentally friendly. Unless some thinking outside the square can be applied. Insinkerators can waste up to 30L of water per day and pollute our waterways! (Food scraps are rich in nitrogen which adds to the natural nutrient load in water causing algal blooms and in turn, increase water temperature & lower oxygen levels for aquatic/marine animals).

They do not allow for valuable food organics to be recovered for recycling: Although waste may not end up in the bin, it does not mean you are reducing it. The organic waste is simply being shifted from landfill to the sewer, then the ocean.

These overriding factors when put together: We don’t want smelly and messy food waste lying around in bags in town waiting for collection but insinkerators are not the answer. What do we do? Fortunately, not one to be put off by a problem no one else has managed to solve or to fly against the advice of the Ministry for the Environment we believe we have come up with the answer.

It’s not the Insinkerator that’s the problem, that’s actually a good thing in terms of waste minimisation and cleanliness around the home and not least of all preventing smelly rubbish, it’s the out put from the insinkerators and the potable water waste that’s the problem.

With FIVE MILE sustainable solution has been found. The ground water is used as a energy source for the heating and cooling is also used as a Green Water system around the town for, irrigation, street cleaning, toilet flushing. With a simple extension of that system we also now have a water supply that is not wasting potable water but making further use of Green Water we have already extracted from the ground as part of the site wide cooling systems and for the insinkerators.

Second problem, the output. Its interesting but in a monthly newsletter produced by a local council; in NSW Australia right next to an article bemoaning the use of Insinkerators was an article that you should use a worm farm instead. Worm Farms and FIVE MILE are not really compatible, maybe for the workers accommodation but not for apartment living and restaurants. But there are more technical versions of Worm Farms. Hot Rot Boxes. These are in effect commercially viable large management solutions for natural and organic waste. Just the same waste that comes out of an Insinkerator.

Combine the two systems and you have a first. A sustainable Insinkerator system. Clean and Green all in one simple system.

## HOTROT SUCCESSFULLY ADDRESSES THE ISSUES OF LARGE SCALE COMPOSTING

In recent times, human activity has disrupted the carbon cycle by harvesting organic material (crops), and disposing of waste to landfills and sewers. This has resulted in a range of problems including landfill leachate and gas, nutrient enrichment of waters, and loss of soil quality. Controlled composting offers a sustainable means of beneficial reuse of waste that will prevent further environmental degradation, improve productive soils and restore the carbon cycle.

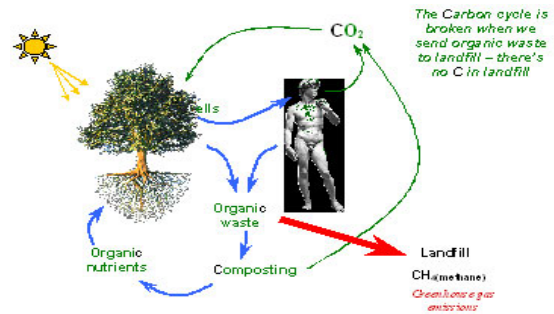

HotRot's unique rotating shaft, process control and other design features confer benefits over other in-vessel systems. HotRot mixes the composting waste during processing. Alternative technologies generally rely on premixing.

HotRot systems are modular in design. This allows for flexibility in plant capacity and extension.

HotRot composting systems are primarily intended to run in a continuous mode.

Material flows transversely through a HotRot unit and short-circuiting or leachate contamination is avoided. Airflow is drawn from the out-feed end of the unit counter-current to material flow. It is impossible for material that has been disinfected, to be re-contaminated with aerosols arising from unprocessed material.

HotRot units are maintained at a negative air pressure as air is drawn through the units. Airtight sealing is not required to prevent fugitive emissions.



## **CONCLUSION**

And as a consultant that's where we fit in... Words from the client brief and our combined Vision with Dave Henderson is to create one of the New Zealand's Most Sustainable Towns.

I believe our efforts to date and the continuing efforts of people like those associated with the project will provide FIVE | MILE with a complete picture of the concept of what constitutes the latest thinking of a sustainable development.

## **ACKNOWLEDGEMENTS**

Apart from all the obvious acknowledgement of all the Green Building and Sustainable information made available from various doctors, professors, engineers and general public from around the world the biggest acknowledgement needs to go to Dave Henderson himself. Not so long ago when the task of building a totally sustainable town was creating havoc with the design concepts Dave Henderson remarked "Now I know why people build large flat roof air conditioned shopping mall"

Yes it's hard. It's much easier to revert to the normal thinking and all have an easy ride. But Dave is above that, nothing normal will be sufficient and his belief for a commercial developer to try and create what FIVE MILE will achieve needs acknowledgement by many.

## **REFERENCES**

Baches, Demetri - Managing Partner, DPZ Pacific. Design team - Personal Communication

Baches, Mallory - Partner, DPZ Pacific. Design team - Personal Communication

Garland, Kyle, Manager Building Sustainability, Department of Sustainability and Environment, Melbourne – "Environmentally Sustainable Design and Construction, Principles and Guidelines" - personal communication?

Henderson, Dave 2006 Five Mile Holdings Ltd & Property Ventures Ltd – "Vision of Five Mile"

Henley, Jane CEO, New Zealand Green Building Council - Personal Communication?

Hitchens, Ken - Director, DPZ Pacific. Design team - Personal Communication

Hobbs, Marian Hon. Minister for the Environment Paper – Major Retailers Workshop 2002

Ministry of the Environment for New Zealand, Govt: towards sustainable practice paper "What is a Sustainable Building". 2006

Prain, Justin 2006, Development Director, Five Mile Holdings Ltd. Design team - Personal Communication

HOTROT Box - Whan, Craig HotRot Composting Systems HotRot Exports Ltd. Santa Barbara, CA.

Wikipedia - The free Web Encyclopedia. 2007 . [www.wikipedia.com](http://www.wikipedia.com)